

**WALL MOUNTED LEAD APRON STORAGE RACK
WITH 5 FULL SWING ARMS**

PRODUCT INFORMATION

PHILLIPS-SAFETY.COM

COPYRIGHT ©2025. ALL RIGHTS RESERVED



PRODUCT INFORMATION

WALL MOUNTED LEAD APRON STORAGE RACK WITH 5 FULL SWING ARMS

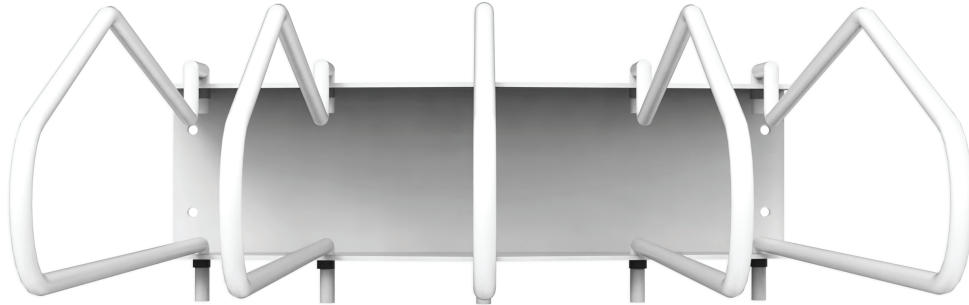

The Wall Mounted Lead Apron Storage Rack with 5 Full Swing Arms is a heavy duty metal rack that offers excellent storage capacity. This Phillips Safety apron rack holds up to five aprons on five arms to a maximum suggested weight of 110 lbs. It features five chromium-plated pivoting hangers, which can flatten out nearly 180 degrees for space saving and storage behind doors, equipment, and more. Each hanger can swing a full 180 degrees to either the left or right. The overall dimensions are 4 5/8" H x 17" W.

SPECIFICATION

MATERIAL: Metal

LEAD APRON CAPACITY: 5

SIZE: 4 5/8" x 17"

FEATURES: Five chromium-plated pivoting hangers, swing 180 degrees to either left or right

WEIGHT CAPACITY: 110 lb

PRODUCT INFORMATION

WALL MOUNTED LEAD APRON STORAGE RACK WITH 5 FULL SWING ARMS

**RAR-F5S
Lead Apron Rack**

**Bracket with
Hangers**

Front View

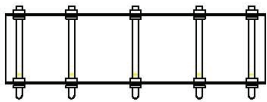

Side View

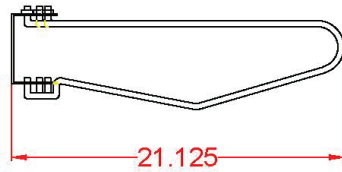

Top View

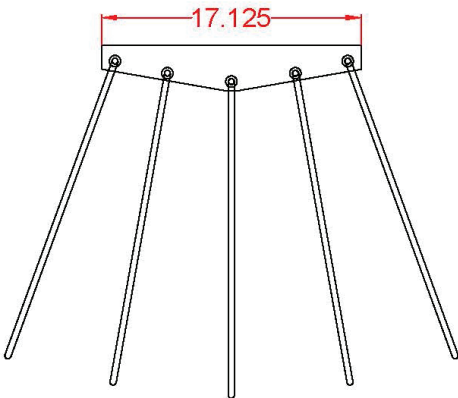

**Bracket
Dimensions**

Front View



Side View

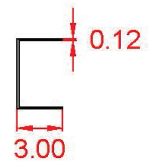

Top View



DRAWING KEY

- LEAD APRON RACK
- HIDDEN LINES
- DIMENSIONS

SCALE: 1:10

PRODUCT INFORMATION

WALL MOUNTED LEAD APRON STORAGE RACK WITH 5 FULL SWING ARMS

CONTACT

Should you need any further information,
please do not hesitate to contact us.

123 Lincoln Blvd, Middlesex, NJ 08846, USA



+1 866 575 1307



service@phillips-safety.com



www.phillips-safety.com



PHILLIPS SAFETY
PRODUCTS INC.

PHILLIPS-SAFETY.COM